

Yale UX Series

Internal Combustion Counterbalanced Forklift

GP20-35UX / 2000 - 3500kg



Riverina Lift Trucks

Yale[®] 
People. Products. Productivity.™

Features

1 High Strength OHG

The overhead guard features profiled steel with high strength glass to enhance reliability and operator protection.

2 Suspension Seat

A full suspension seat that offers excellence in comfort, with an operator presence system fitted as standard.

3 Low Step Driver Height

Convenient step placing to suit a variety of heights to ensure easy access to the truck at all times.



4 Wide View Mast

The wide mast features an outside width of 720mm. It can significantly improve the driver's front field of view while increasing the safety and comfort of operating the truck.

5 Small Steering Wheel

The adjustable steering wheel is convenient for the operator as it provides 8 degrees of adjustment. It is also easy to navigate when working in narrow spaces.

6 Japanese Engine

The UX Japanese engine provides reliability and ease for sourcing replacement parts.

GP20-35UX

The Yale® UX Series provides the ideal solution to meet your less frequent usage needs, without compromising on performance.

▶ The Range

The range consists of 2,000 - 3,500kg. IC counterbalance, pneumatic tyre forklift trucks, available in four different capacities:

2,000kg – GP20UX / 2,500kg – GP25UX
3,000kg – GP30UX / 3,500kg – GP35UX

Each model is available with diesel, LPG or dual-fuel power, a single-speed powershift transmission and a range of front end equipment options to suit varying application requirements.

▶ Easy to Operate

The ergonomically designed operator compartment, with a familiar automotive layout, means that drivers will be able to work comfortably. A range of standard features and options help to ensure that the truck is configured to the needs of the application.

▶ Serviceability

Due to the simplicity of the components and specifications, servicing can be carried out quickly and easily.

▶ Low Cost of Ownership

The use of high quality, robust components, efficient filtration and excellent cooling helps contribute to reliable operations and lower wear and tear. This, together with the fast availability of cost-effective replacement parts helps to reduce service and maintenance requirements and costs.

▶ Comfort

- Yale special display with 3.5" LCD
- Large foot room on floor plate
- Dual suspension system
- Hand parking brake lever with button greatly reduces fatigue in operation
- Small diameter steering wheel with adjustable steering column

▶ Safety and Stability

- Wide view mast
- High strength overhead guard
- Muffler and engine protective system
- Low centre of gravity

▶ Easy Maintenance

- Large access area for service and repairs
- Simple components
- Computer-based diagnostics not required

▶ Reliability and Exchangeability

- Triplex plate overhead guard
- Exchangeable components across models

▶ Environmental Protection

- Noise isolation material
- Environmentally-aware design

Engineered for drivers with Comfort, Safety and Ergonomics



▶ Yale Display with 3.5" LCD

- The Yale UX Series Forklift adopts a 3.5" LCD display, providing convenient viewing of the display data when driving and operating



▶ Hand Parking Brake

- Low effort to operate park brake lever
- Hand parking brake lever with button reduces operator fatigue



▶ Large Foot Room

- Spacious foot room design provides comfort, convenience and safety
- Control pedals provide extra foot space which reduces operator fatigue and increases operator comfort

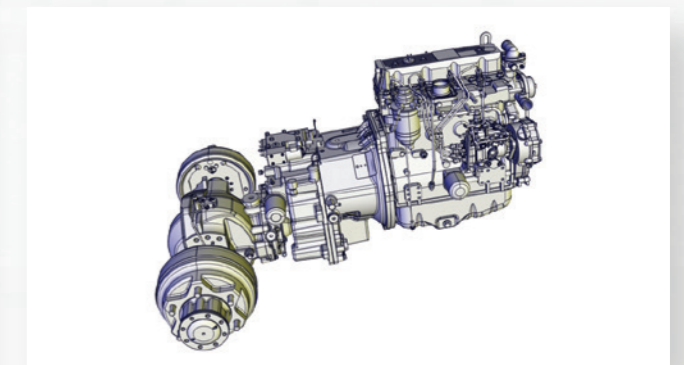

▶ Dual Suspension System

- The specialised dual-suspension system decreases vibration and noise
- Full floating safeguard/cabin system
- Engine vibration damper
- Suspended transmission replaces traditional rigid connections



▶ Small Diameter Steering Wheel with Adjustable Steer Column

- The 300mm diameter steering wheel is easy to manipulate, responsive, and ensures optimum mobility when working in a narrow space
- The ideally positioned steering wheel allows 8 degrees of adjustment, to suit a variety of different operators



▶ High Strength Overhead Guard

- Profiled steel overhead guard
- High strength roof with high strength glass enhances reliability and operator protection
- Mast composite roller structure



▶ Suspension Seat

- Full suspension seat offers excellent comfort
- Operator presence system as standard

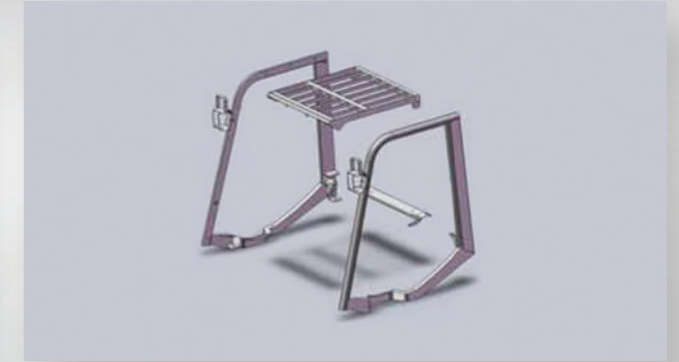

▶ Triplex Plate Overhead Guard

- The overhead guard is developed using three pieces; left side, right side and top canopy making replacement more convenient



▶ Wide View Mast

- The wide view mast with an outside width of 720mm, significantly improves the driver's front field of view, reduces blind spots, and increases the safety and comfort of the operation



▶ Large Access Area for Service and Repairs

- Large access space to engine compartment makes service and repairs more convenient



▶ Exchangeable Components

- Engine cover, instrument panel, display and most other components are exchangeable with other capacities in the same range
- Front fenders adaptable to single or dual wheel configuration

▶ Improved Lifting Speed

- Competitive lifting speeds

Options

Yale UX Series trucks feature a comprehensive range of standard equipment, with a number of options available to suit the specific needs of your application, including:

- LPG, dual-fuel or diesel
- Pneumatic-shaped solid, or dual tyres
- Various fork lengths
- Integral sideshift
- Swing-out drop down LPG bracket
- Rear, LED work light
- Strobe light
- Backup alarm
- High air intake with pre-cleaner
- Tilt cylinder boots
- Various mast heights
- 3 way catalytic purifier on LPG engines
- Glass roof
- Front window with wiper

Please refer to the Price List for full option configurations.

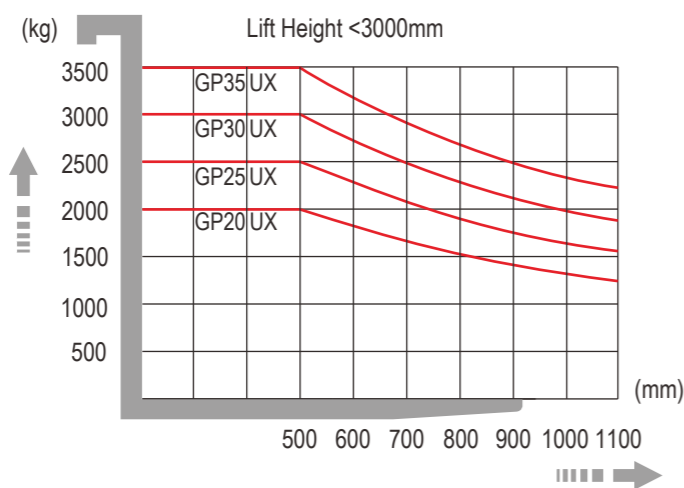
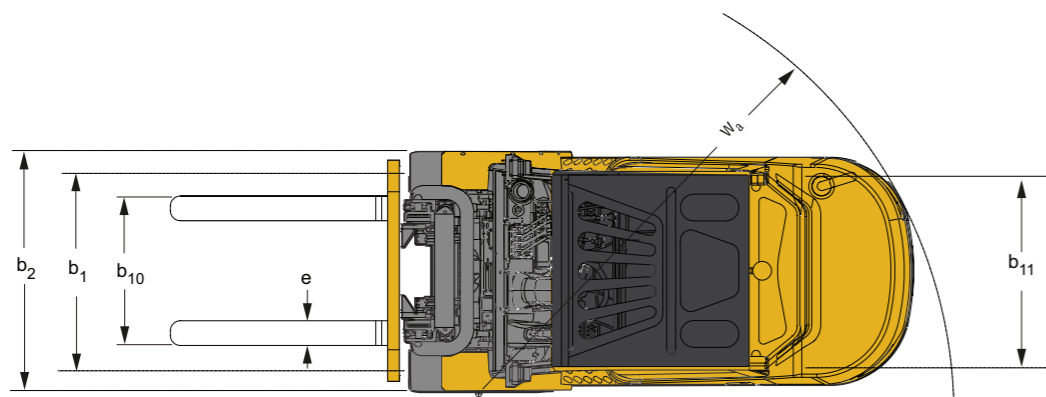
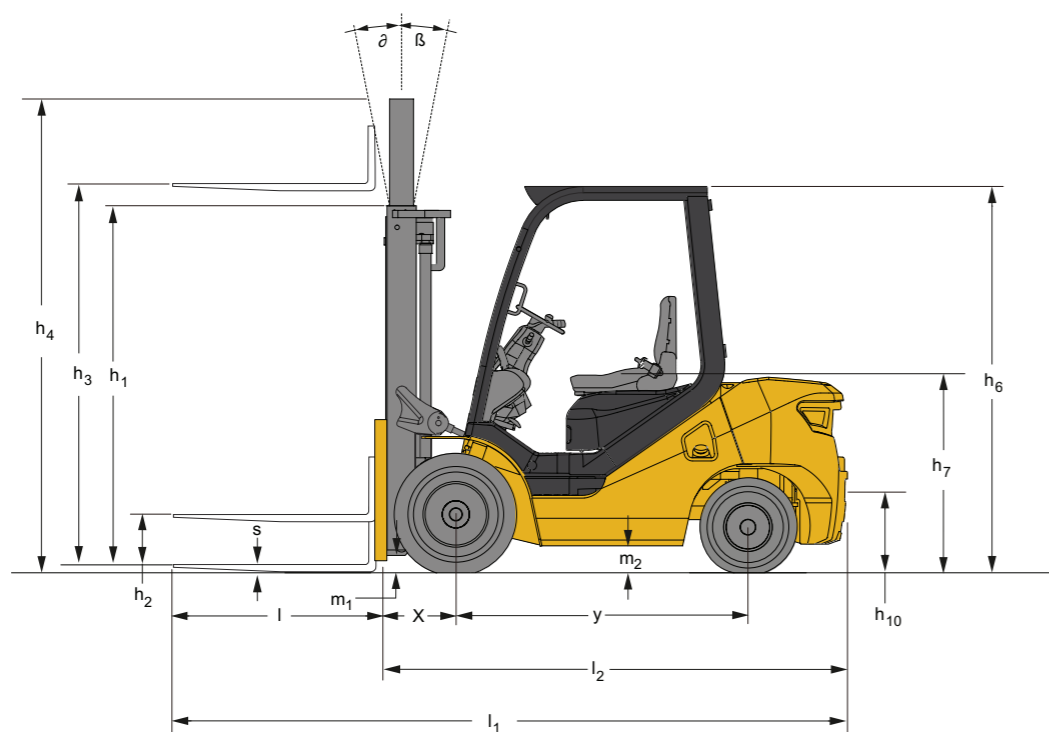

GP20UX Rated Capacity KG @ 500MM and 600MM Load Centre

	Maximum fork height $h_s + s$ (mm)	Mast tilt		Lowered height h_1 (mm)	Extended height h_1 (mm) (1)	Extended height h_1 (mm) (2)	Free lift height $h_s + s$ (mm) (1)	GP20UX without sideshift			
		FWD tilt (°)	Back tilt (°)					Solid Tyres		Pneumatic Tyres	
								500 mm LC	600 mm LC	500 mm LC	600 mm LC
2-STAGE LIMITED FREE LIFT	4000	6	6	2560	4575	4990	160	2000	1830	2000	1830
	4500	6	6	2810	5075	5490	160	1940	1740	1900	1740
	5000	6	6	3060	5575	5990	160	1800	1640	1800	1630
2 STG FFL	3000	6	12	2010	3590	3990	1420	2000	1830	2000	1830
	4500	6	6	2060	5017	5490	1440	1810	1650	1810	1640
3-STAGE FULL FREE LIFT	4800	6	6	2160	5317	5790	1540	1750	1590	1750	1580
	5500	3	6	2425	6017	6490	1800	1590	1440	1540	1430
	6000	3	6	2610	6517	6990	1990	1450	1320	1240	1250

GP25UX Rated Capacity KG @ 500MM and 600MM Load Centre

	Maximum fork height $h_s + s$ (mm)	Mast tilt		Lowered height h_1 (mm)	Extended height h_1 (mm) (1)	Extended height h_1 (mm) (2)	Free lift height $h_s + s$ (mm) (1)	GP25UX without sideshift			
		FWD tilt (°)	Back tilt (°)					Solid Tyres		Pneumatic Tyres	
								500 mm LC	600 mm LC	500 mm LC	600 mm LC
2-STAGE LIMITED FREE LIFT	4000	6	6	2560	4575	4990	160	2500	2300	2500	2300
	4500	6	6	2810	5075	5490	160	2390	2200	2390	2190
	5000	6	6	3060	5575	5990	160	2280	2080	2270	2070
2 STG FFL	3000	6	12	2010	3590	3990	1420	2500	2290	2500	2290
	4500	6	6	2060	5017	5490	1440	2300	2080	2290	2080
3-STAGE FULL FREE LIFT	4800	6	6	2160	5317	5790	1540	2220	2020	2100	2010
	5500	3	6	2425	6017	6490	1800	2020	1850	1550	1550
	6000	3	6	2610	6517	6990	1990	1620	1630	1200	1220

GP30UX Rated Capacity KG @ 500MM and 600MM Load Centre

	Maximum fork height $h_s + s$ (mm)	Mast tilt		Lowered height h_1 (mm)	Extended height h_1 (mm) (1)	Extended height h_1 (mm) (2)	Free lift height $h_s + s$ (mm) (1)	GP30UX without sideshift			
		FWD tilt (°)	Back tilt (°)					Solid Tyres		Pneumatic Tyres	
								500 mm LC	600 mm LC	500 mm LC	600 mm LC
2-STAGE LIMITED FREE LIFT	4000	6	6	2625	4640	5100	165	2860	2590	2850	2590
	4500	6	6	2875	5140	5600	165	2740	2480	2730	2480
	5000	6	6	3125	5640	6100	165	2600	2370	2350	2210
2 STG FFL	3000	6	12	2075	3650	4100	1425	2910	2650	2910	2650
	4500	6	6	2125	5100	5600	1525	2890	2780	2880	2690
3-STAGE FULL FREE LIFT	4800	6	6	2225	5400	5900	1625	2820	2730	2810	2650
	5500	3	6	2490	6100	6600	1880	2630	2610	2220	2180
	6000	3	6	2675	6600	7100	2075	2280	2250	1820	1800

GP35UX Rated Capacity KG @ 500MM and 600MM Load Centre

	Maximum fork height $h_s + s$ (mm)	Mast tilt		Lowered height h_1 (mm)	Extended height h_1 (mm) (1)	Extended height h_1 (mm) (2)	Free lift height $h_s + s$ (mm) (1)	GP35UX without sideshift			
		FWD tilt (°)	Back tilt (°)					Solid Tyres		Pneumatic Tyres	
								500 mm LC	600 mm LC	500 mm LC	600 mm LC
2-STAGE LIMITED FREE LIFT	4000	6	6	2700	4700	5100	170	3430	3340	3280	2990
	4500	6	6	2950	5200	5600	170	3320	3080	2770	2560
	5000	6	6	3200	5700	6100	170	2850	2640	2310	2160
2 STG FFL	3000	6	12	2150	3680	4100	1470	3500	3500	3500	3460
	4500	6	6	2200	5140	5600	1560	3380	3270	3290	3140
3-STAGE FULL FREE LIFT	4800	6	6	2300	5440	5900	1660	3310	3220	2920	2810
	5500	3	6	2526	6140	6600	1915	2760	2690	2180	2130
	6000	3	6	2750	6640	7100	2110	2240	2210	1720	1700

Note: For integral sideshift deduct 50Kg from stated capacity, (1) = without LBR (2) with LBR, all ratings with 1070 mm forks

	1.1	Manufacturer (abbreviation)	YALE					
			YALE	YALE	YALE	YALE	YALE	YALE
Distinguishing Marks	1.2	Manufacturer's type designation	GDP20UX	GDP25UX	GDP30UX	GDP30UX	GDP35UX	GDP35UX
		Engine / transmission	Yanmar 2.6L	Yanmar 2.6L	Yanmar 3.0L	Yanmar 3.3L	Yanmar 3.0L	Yanmar 3.3L
	1.3	Drive: electric (battery or mains), diesel, petrol, fuel gas	DIESEL	DIESEL	DIESEL	DIESEL	DIESEL	DIESEL
	1.4	Operator type: hand, pedestrian, standing, seated, order-picker	Seated	Seated	Seated	Seated	Seated	Seated
	1.5	Rated capacity/rated load	Q (kg)	2000	2500	3000	3000	3500
	1.6	Load centre distance	c (mm)	500	500	500	500	500
	1.8	Load distance, centre of drive axle to fork	x (mm)	475	475	490	490	510
	1.9	Wheelbase	y (mm)	1600	1600	1700	1700	1700
	Weights	2.1	Service weight	kg	3390	3650	4300	4300
2.2		Axle loading, laden front / rear	kg	4760 / 630	5320 / 650	6490 / 770	6490 / 810	7250 / 960
2.3		Axle loading, unladen front / rear	kg	1540 / 1850	1500 / 2150	1710 / 2590	1710 / 2590	1690 / 3020
Tyres/Chassis	3.1	Tyre type		Pneumatic	Pneumatic	Pneumatic	Pneumatic	Pneumatic
	3.2	Tyre size, front		7.00-12NHS-12	7.00-12NHS-12	28x9-15NHS-14PR	28x9-15NHS-14PR	28x9-15NHS-14PR
	3.3	Tyre size, rear		6.00-9NHS-10	6.00-9NHS-10	6.500-10NHS-10PR	6.500-10NHS-12PR	6.500-10NHS-10PR
	3.5	Wheels, number front/rear (X = driven wheels)		2X/2	2X/2	2X/2	2X/2	2X/2
	3.6	Tread, front	b10 (mm)	970	970	1000	1000	1000
	3.7	Tread, rear	b11 (mm)	980	980	970	970	970
	Dimensions	4.1	Tilt of mast / fork carriage forward / backward	(°)	6 / 12	6 / 12	6 / 12	6 / 12
4.2		Height, mast lowered	h10 (mm)	2010	2010	2075	2075	2150
4.3		Free lift	h2 (mm)	160	160	165	165	165
4.4		Lift	h3 (mm)	3000	3000	3000	3000	3000
4.5		Height of mast, extended wo / LBR	h4 (mm)	3575	3575	3640	3640	3700
4.5		Height of mast, extended w / LBR	h4 (mm)	4025	4025	4140	4140	4140
4.7		Height of overhead guard	h6 (mm)	2180	2180	2205	2205	2205
4.8		Seat height / stand height	h7 (mm)	1167	1167	1192	1192	1192
4.12		Coupling height	h10 (mm)	250	250	480	480	480
4.19		Overall length	l1 (mm)	3630	3690	3804	3804	3894
4.20		Length to face of forks	l2 (mm)	2560	2620	2734	2734	2824
4.21		Overall width (Standard / Dual)	b1/b2 (mm)	1150 / 1590	1150 / 1590	1210 / 1650	1210 / 1650	1210 / 1650
4.22		Fork dimensions	s/e/l (mm)	40 x 122 x 1070	40 x 122 x 1070	45 x 122 x 1070	45 x 122 x 1070	45 x 122 x 1070
4.23		Fork carriage to DIN 15173. Class, A/B		A	A	A	A	A
4.24		Fork carriage width	b3 (mm)	1040	1040	1100	1100	1100
4.31		Ground clearance, laden, below mast	m1 (mm)	125	125	130	130	130
4.32		Ground clearance, centre of wheelbase	m2 (mm)	150	150	145	145	145
4.34.1		Aisle width with pallets 1000 long x 1200 wide	Ast (mm)	3966	4026	4126	4126	4210
4.34.2		Aisle width with pallets 800 wide x 1200 long	Ast (mm)	3766	3826	3926	3926	4010
4.35		Turning radius	Wa (mm)	2290	2350	2430	2430	2500
4.36		Internal turning radius	b13 (mm)	136	136	203	203	203
4.42	Step height (from ground to running board)	k (mm)	430	430	455	455	455	
Performance Data	5.1	Travel speed, laden / unladen	km/h	20 / 20	20 / 20	20 / 20	18 / 19	18 / 19
	5.2	Lift speed, laden / unladen	m/s	0.54 / 0.57	0.54 / 0.57	0.46 / 0.49	0.42 / 0.45	0.33 / 0.36
	5.3	Lowering speed, laden / unladen	m/s	0.43 / 0.40	0.43 / 0.40	0.38 / 0.36	0.4 / 0.38	0.4 / 0.38
	5.5	Drawbar pull, laden / unladen @ 1.6 km/h	N	10219/8589	10118/8259	12875/9498	13553/9498	13516/9676
	5.5	Drawbar pull, laden / unladen @ 4.8 km/h	N	4879/7544	4879/7185	8498/8119	7319/8119	8879/8892
	5.6	Max. drawbar pull, laden / unladen	N	12774/8761	12648/8450	16094/9688	16941/9688	16870/9676
	5.7	Gradeability, laden / unladen @ 4.8 km/h	%	10/19	10/19	11/19	14/19	11/19
	5.8	Max. gradeability, laden / unladen @ 1.6 km/h	%	19/25	19/25	17/23	19/25	17/23
	5.10	Service brake		Hydraulic	Hydraulic	Hydraulic	Hydraulic	Hydraulic
	Combustion Engine	7.1	Engine manufacturer/type		Yanmar 2.6L	Yanmar 2.6L	Yanmar 3.0L	Yanmar 3.3L
7.2		Engine power according to ISO 1585	kW	33	33	35.5	42.1	35.5
7.3		Rated speed	min-1	2450	2450	2400	2300	2400
7.4		Number of cylinders/displacements	(-)/cm3	4 / 2659	4 / 2659	4 / 3054	4 / 3319	4 / 3054
7.5		Fuel consumption according to VDI cycle	l/h or kg/h	☞	☞	☞	☞	☞
Additional Data	8.1	Type of drive unit		Automatic	Automatic	Automatic	Automatic	Automatic
	10.1	Operating pressure for attachments	bar	0-175	0-175	0-175	0-175	0-175
	10.2	Oil volume for attachments	l/min	64	64	64	64	64
	10.7	Average noise level at operator's ear (no cab)	dB(A)	84	84	84	84	84
	10.7.1	Guaranteed sound power 2001/14/EC	dB(A)	104	104	104	104	104
10.8	Towing coupling, type DIN		PIN	PIN	PIN	PIN	PIN	

	1.1	Manufacturer	YALE					
			YALE	YALE	YALE	YALE	YALE	YALE
Distinguishing Marks	1.2	Manufacturer's type designation	GLP20UX	GLP20UX	GLP25UX	GLP25UX	GLP30UX	GLP35UX
		Engine / transmission	GCT K21	GCT K25	GCT K21	GCT K25	GCT K25	GCT K25
	1.3	Drive: electric (battery or mains), diesel, petrol, fuel gas	LPG / PETROL	LPG / PETROL	LPG / PETROL	LPG / PETROL	LPG / PETROL	LPG / PETROL
	1.4	Operator type: hand, pedestrian, standing, seated, order-picker	Seated	Seated	Seated	Seated	Seated	Seated
	1.5	Rated capacity/rated load	Q (kg)	2000	2000	2500	2500	3000
	1.6	Load centre distance	c (mm)	500	500	500	500	500
	1.8	Load distance, centre of drive axle to fork	x (mm)	475	475	475	475	490
	1.9	Wheelbase	y (mm)	1600	1600	1600	1600	1700
	Weights	2.1	Service weight	kg	3390	3390	3650	3650
2.2		Axle loading, laden front / rear	kg	4760 / 630	4760 / 630	5400 / 650	5400 / 650	6490 / 810
2.3		Axle loading, unladen front / rear	kg	1540 / 1850	1540 / 1850	1500 / 2150	1500 / 2150	1710 / 2590
Tyres/Chassis	3.1	Tyre type		Pneumatic	Pneumatic	Pneumatic	Pneumatic	Pneumatic
	3.2	Tyre size, front		7.00-12NHS-12	7.00-12NHS-12	7.00-12NHS-12	7.00-12NHS-12	28x9-15NHS-14PR
	3.3	Tyre size, rear		6.00-9NHS-10	6.00-9NHS-10	6.00-9NHS-10	6.00-9NHS-10	6.500-10NHS-14PR
	3.5	Wheels, number front/rear (X = driven wheels)		2X/2	2X/2	2X/2	2X/2	2X/2
	3.6	Tread, front	b10 (mm)	970	970	970	970	1000
	3.7	Tread, rear	b11 (mm)	980	980	980	980	970
	Dimensions	4.1	Tilt of mast / fork carriage forward / backward	(°)	6 / 12	6 / 12	6 / 12	6 / 12
4.2		Height, mast lowered	h10 (mm)	2010	2010	2010	2010	2075
4.3		Free lift	h2 (mm)	160	160	160	160	165
4.4		Lift	h3 (mm)	3000	3000	3000	3000	3000
4.5		Height of mast, extended wo / LBR	h4 (mm)	3575	3575	3575	3575	3640
4.5		Height of mast, extended w / LBR	h4 (mm)	4025	4025	4025	4025	4140
4.7		Height of overhead guard	h6 (mm)	2180	2180	2180	2180	2205
4.8		Seat height / stand height	h7 (mm)	1167	1167	1167	1167	1192
4.12		Coupling height	h10 (mm)	250	250	250	250	480
4.19		Overall length	l1 (mm)	3630	3630	3690	3690	3804
4.20		Length to face of forks	l2 (mm)	2560	2560	2620	2620	2734
4.21		Overall width (Standard / Dual)	b1/b2 (mm)	1150 / 1590	1150 / 1590	1150 / 1590	1150 / 1590	1210 / 1650
4.22		Fork dimensions	s/e/l (mm)	40 x 122 x 1070	40 x 122 x 1070	40 x 122 x 1070	40 x 122 x 1070	45 x 122 x 1070
4.23		Fork carriage to DIN 15173. Class, A/B		A	A	A	A	A
4.24		Fork carriage width	b3 (mm)	1040	1040	1040	1040	1100
4.31		Ground clearance, laden, below mast	m1 (mm)	125	125	125	125	130
4.32		Ground clearance, centre of wheelbase	m2 (mm)	150	150	150	150	145
4.34.1		Aisle width with pallets 1000 long x 1200 wide	Ast (mm)	3966	3966	4026	4026	4126
4.34.2		Aisle width with pallets 800 wide x 1200 long	Ast (mm)	3766	3766	3826	3826	3926
4.35		Turning radius	Wa (mm)	2290	2290	2350	2350	2430
4.36		Internal turning radius	b13 (mm)	136	136	136	136	203
4.42	Step height (from ground to running board)	k (mm)	430	430	430	430	455	
Performance Data	5.1	Travel speed, laden / unladen	km/h	18 / 18	19 / 19	18 / 18	17.5 / 18	18 / 19
	5.2	Lift speed, laden / unladen	m/s	0.49 / 0.52	0.50 / 0.53	0.49 / 0.52	0.50 / 0.53	0.40 / 0.43
	5.3	Lowering speed, laden / unladen	m/s	0.43 / 0.40	0.42 / 0.39	0.43 / 0.40	0.42 / 0.39	0.40 / 0.38
	5.5	Drawbar pull, laden / unladen @ 1.6 km/h	N	12880/12880	12711/8589	12800/12800	12585/8259	14720/14720
	5.5	Drawbar pull, laden / unladen @ 4.8 km/h	N	9660/9600	6872/7544	9975/9975	6872/7185	11500/11500
	5.6	Max. drawbar pull, laden / unladen	N	15575/15575	16651/8761	15575/15575	16790/8450	17480/17480
	5.7	Gradeability, laden / unladen @ 4.8 km/h	%	13/19	13/19	11/19	11/19	11/19
	5.8	Max. gradeability, laden / unladen @ 1.6 km/h	%	17/23	17/23	19/25	19/25	19/25
	5.10	Service brake		Hydraulic	Hydraulic	Hydraulic	Hydraulic	Hydraulic
	Combustion Engine	7.1	Engine manufacturer/type		GCT K21 LPG	GCT K25	GCT K21 LPG	GCT K25
7.2		Engine power according to ISO 1585	kW	31.2	37.4	31.2	37.4	37.4
7.3		Rated speed	min-1	2250	2300	2250	2300	2300
7.4		Number of cylinders/displacements	(-)/cm3	4 / 2065	4 / 2488	4 / 2065	4 / 2488	4 / 2488
7.5		Fuel consumption according to VDI cycle	l/h or kg/h	☞	☞	☞	☞	☞
Additional Data	8.1	Type of drive unit		Automatic	Automatic	Automatic	Automatic	Automatic
	10.1	Operating pressure for attachments	bar	0-175	0-175	0-175	0-175	0-175
	10.2	Oil volume for attachments	l/min	64	64	64	64	64
	10.7	Average noise level at operator's ear (no cab)	dB(A)	84	84	84	84	84
	10.7.1	Guaranteed sound power 2001/14/EC	dB(A)	103	103	103	103	103
10.8	Towing coupling, type DIN		PIN	PIN	PIN	PIN	PIN	

Yale® Dealers

Contact your nearest
Yale® Dealership by visiting
www.yale.com.au



Contact your local Yale® Dealer

Riverina Lift Trucks
42-46 Wakaden Street
Griffith NSW 2680
Phone: 02 6962 6255
Email: rltsales@rlt.com.au

Yale Pacific

1 Bullecourt Avenue, Milperra NSW, Australia 2214
Tel: +61 (2) 9795 3800 | Fax: +61 (2) 9792 8484
yale.com/pacific/en-au

Yale Asia

16 Tuas Avenue 20, Singapore 638827
Tel: +65 6863 3387 | Fax: +65 6863 3349
yale.com/asia/en-sg

Yale, and PEOPLE. PRODUCTS. PRODUCTIVITY are trademarks of Hyster-Yale Group, Inc.
® is a registered copyright of Hyster-Yale Group, Inc.

©Yale Asia Pacific 2020. All rights reserved. Specifications and details in this brochure are subject to change without prior notification.

www.yale.com.au



Manufactured in our own ISO 9001 and 14001 Registered Facilities

Trucks may be shown with optional equipment.

Yale®
People. Products. Productivity.™