

# Yale UX Series

Electric Walkie Pallet Truck

MP15UX / 1500kg

**\$ 3,750**  
incl GST



**Riverina Lift Trucks**



People. Products. Productivity.™

# MP15UX

The Yale® electric walkie pallet truck MP15UX demonstrates intelligent ergonomics, reliable technology and energy efficient features to facilitate operational needs. The low-maintenance design promotes increased productivity and helps reduce operational costs.

## ► Productivity

- Small turning radius (1454 mm)
- Performs well on gradients
- Long handle reduces steering effort
- Drive capability when tiller is upright, greatly reduces turning space
- Entry roller for easy operation
- Variable speed control
- Built-in charger
- Low speed switch in the handle
- Floating balance wheel automatically adjusts height and improves stability when unloading

## ► Safety Features

- Emergency stop button
- Emergency reversing belly button
- Casters to increase stability

## ► Optimum Structural Design

- Formed heavy gauge steel provides maximum fork strength and longevity
- Pull rod design protects against bending
- Durable plastic covers
- Compact and lightweight design

## ► Serviceability

- Fast and efficient servicing
- Simple components
- Computer-based diagnostics not required
- Sealed maintenance free batteries
- Tandem wheel option available



Handle (Standard)  
(Left and Right Handed)



Entry roller for  
easy operation

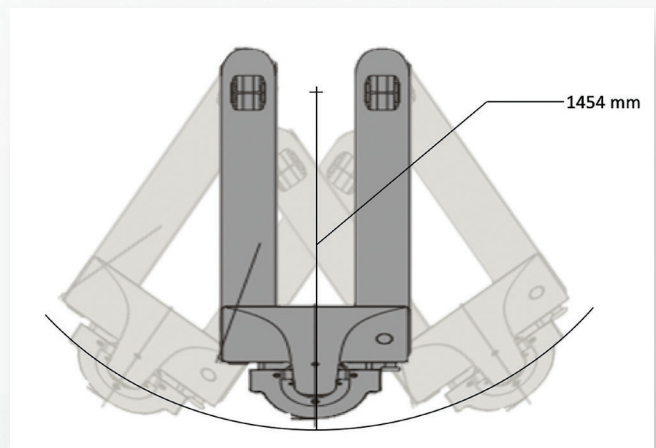

Small turning radius

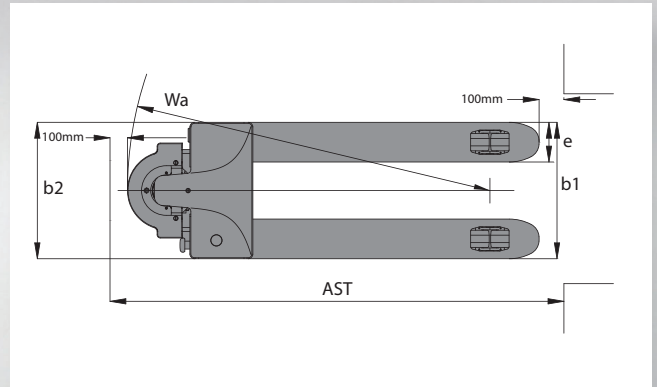
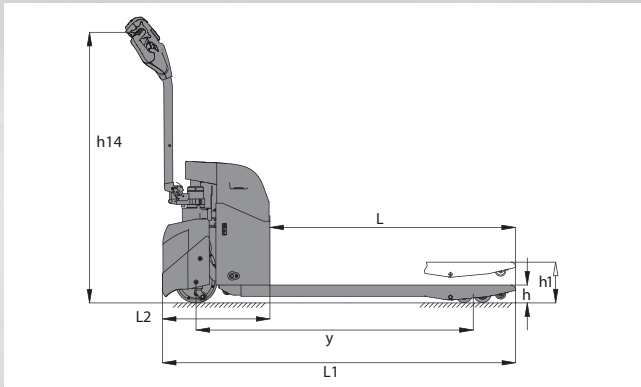

Model	Measurement	MP15UX
Power Type		24-volt
Operator Type		Pedestrian
Rated Capacity	kg	1500
Load Center	mm	600
Fork Length	L (mm)	1150
Fork Overall Width	b1 (mm)	685 / 520
Fork Width (Individual Fork)	e (mm)	160
Wheelbase (Raised/Lowered)	y (mm)	1287 / 1357
Overall Length	L1 (mm)	1654
Outside Turning Radius (Raised)	Wa (mm)	1454
Right Angle Stack (1000mm x 1200mm Crossways)	AST (mm)	1854
Overall Lift Height – Top of Forks	h1 (mm)	190
Lowered Height – Top of Forks	h (mm)	75
Total Lift	mm	115
Truck Overall Width	b2 (mm)	685 / 562
Chassis Length	L2 (mm)	504
Height of Tiller (max.)	h14 (mm)	1270
Battery Compartment – Standard	mm	228 / 138 / 214
Maximum Gradeability (Loaded/Unloaded)	%	5% / 10%
Maximum Travel Speed (Loaded/Unloaded)	kph	4.3 / 4.8
Traction Motor Control Method Type		DC
Service Brake Type		Electric
Truck Weight (approximate) with battery - NL/RL	kg	205 / 1705
Drive Tyre – Size/Type (Number of Wheels)	mm	φ195 x 70 Poly (1)
Load Wheel – Size/Type (Number of Wheels)	mm	φ74 x 90 Poly Single / φ74 x 70 Poly Tandem
Battery Type		Sealed
Battery Ampere Hours	Ah	65
Battery Weight	kg	36
On Board Charger	V	100-240

 **MP15UX Power Plug Type**

